

气动机械增压缸 FM Force multipliers FM

主要特点:

- 紧凑型设计
- 气缸缸径 100 mm
- 4 种行程可选
- 2 种氮化的活塞杆可选
- 恒定的力
- 夹紧位置有液压缓冲器
- 青铜导向衬套

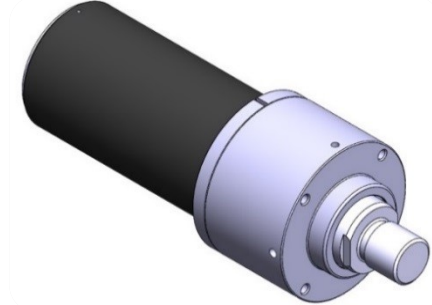

Main characteristics:

- Compact design
- Cylinder bore 100 mm
- 4 different types of stroke
- 2 nitried rods
- Costant force
- Shock absorber in closing phase
- Bronze guiding bushings



[PDF](#)



[3D Step](#)



[Index](#)

索引.

Index.

页码 Page	描述 Description	
1	主要特点 Main characteristics	
2	订货举例 Ordering example	
3	尺寸页码 Dimensional page	FM100-...A
4		FM100-...B
5	气路图 Pneumatic plan	
6	备件 / Spare parts	
6	备注 / Notes	



订货举例.

Ordering example.

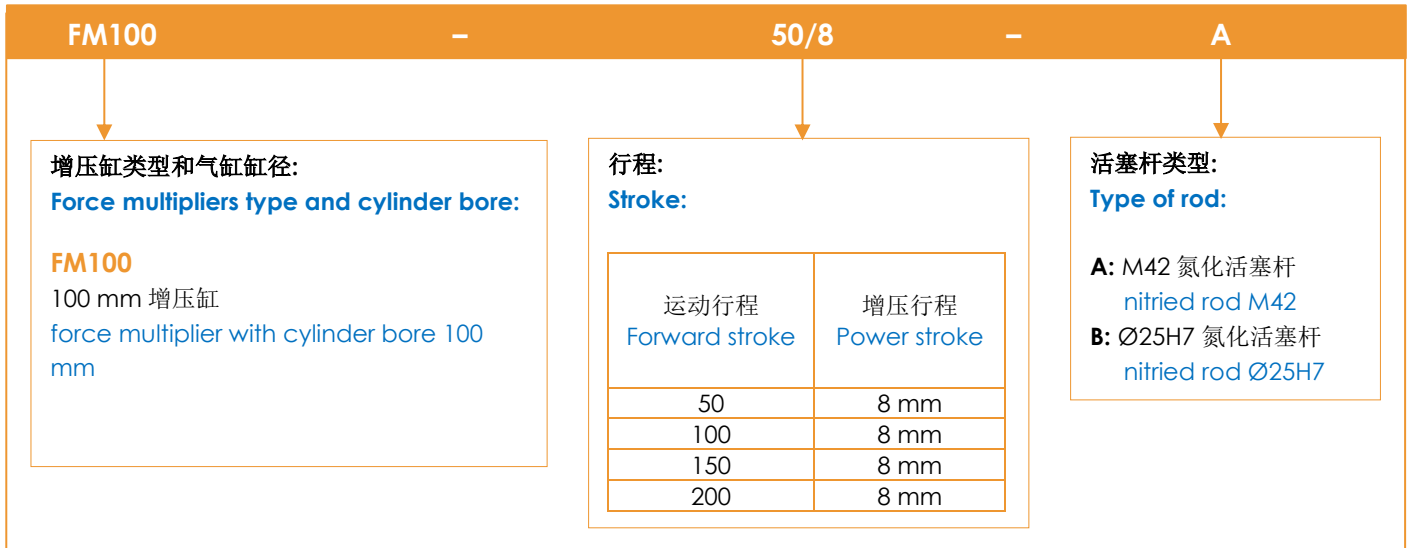



FM100-...A

增压缸, D.100 缸径, 增压行程 8mm, M42 螺纹连接
Force multipliers, D.100, Power stroke 8 mm, Connection M42

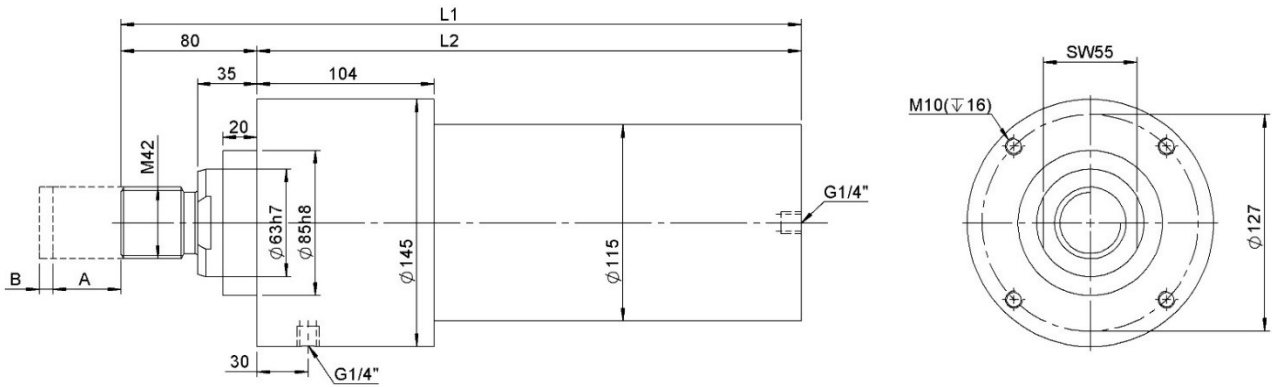

#公差: 定位销孔: ± 0.02 | 螺纹孔: ± 0.1

#Tolerances: dowel holes: ± 0.02 | screw holes: ± 0.1

类型 Type	气缸 Cylinder	推进行程 Forward stroke A	增压行程 Power stroke B	L1	L2	重量 Weight
	[mm]	[mm]	[mm]	[mm]	[mm]	[Kg]
FM100-50/8-A	100	50	8	400	320	~ 20.5
FM100-100/8-A		100		450	370	~ 22.5
FM100-150/8-A		150		500	420	~ 24.5
FM100-200/8-A		200		550	470	~ 26.5

工作气压 Working pressure	增压力 (6 bar) Thrust force (6 bar)	气缸推进力 (6 bar) Approaching stroke force (6bar)	气缸返回力 (6 bar) Return stroke force (6 bar)
[bar]	[daN]	[daN]	[daN]
3 - 6	4500	460	270



FM100-...B

增压缸, D.100 缸径, 增压行程 8mm, Ø25h7 连接

Force multipliers, D.100, Power stroke 8 mm, Connection Ø25h7

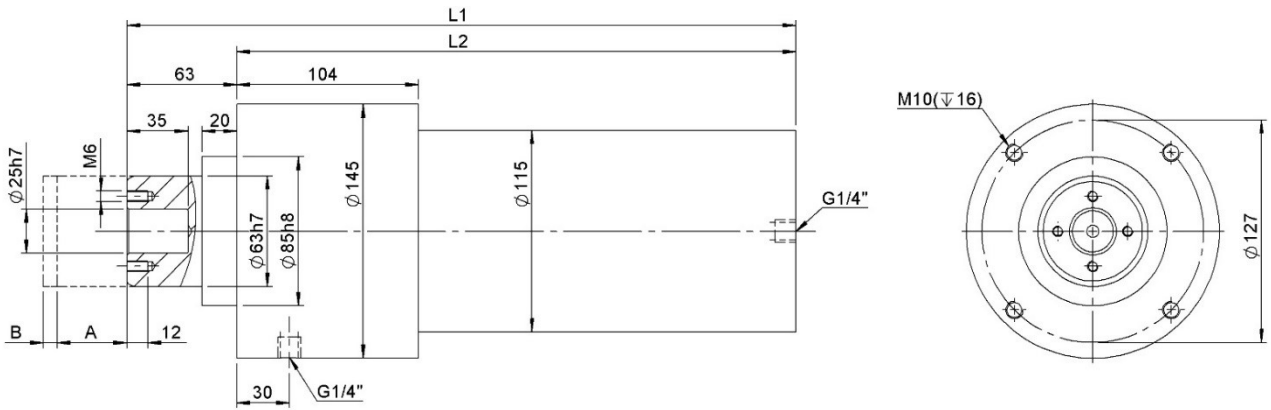

公差: 定位销孔: ±0.02 | 螺纹孔: ±0.1

#Tolerances: dowel holes: ±0.02 | screw holes: ±0.1

类型 Type	气缸 Cylinder	推进行程 Forward stroke A	增压行程 Power stroke B	L1	L2	重量 Weight
	[mm]	[mm]	[mm]	[mm]	[mm]	[Kg]
FM100-50/8-B	100	50	8	400	320	~ 20.5
FM100-100/8-B		100		450	370	~ 22.5
FM100-150/8-B		150		500	420	~ 24.5
FM100-200/8-B		200		550	470	~ 26.5

工作气压 Working pressure	增压力 (6 bar) Thrust force (6 bar)	气缸推进力 (6 bar) Approaching stroke force (6 bar)	气缸返回力 (6 bar) Return stroke force (6 bar)
[bar]	[daN]	[daN]	[daN]
3 - 6	4500	460	270

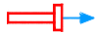

气路图.

Pneumatic plant.

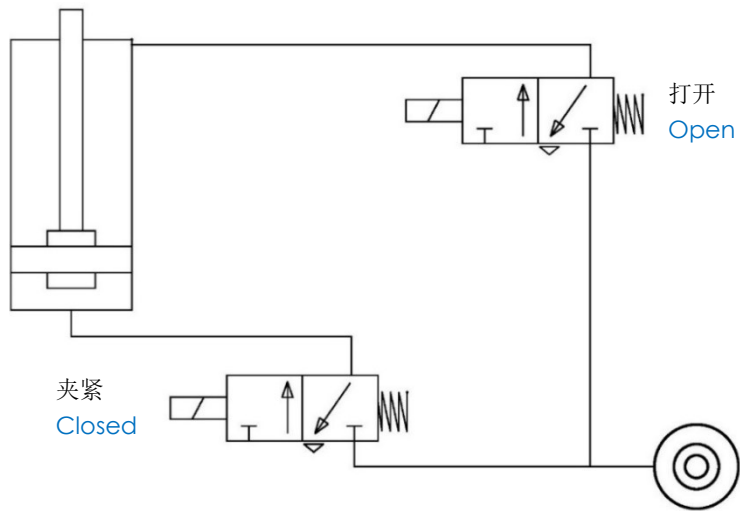

类型 Type	空气耗气量 Air consumption (5 bar)
	[1]
FM100-50/8-A	~ 4,5
FM100-100/8-A	~ 9
FM100-150/8-A	~ 13
FM100-200/8-A	~ 17,5



备件.

Spare parts.

# Kit	图片 Picture	描述 Description	代号 Article
密封圈组件 Seals kit		100 mm气缸密封圈组件 Seal components for pneumatic cylinder bore 100 mm	SCR-FM100

这个目录取消并替换了以前的目录。我们保留在没有任何通知的情况下进行添加或更改的权利。产品目录中的产品是标准的;任何特殊申请的查询都由技术/销售部门评估。完整的文档属于VEP自动化s.r.l, 未经许可, 任何形式的复制都是禁止的。

This catalogue cancels and replaces the previous ones. We reserve the right to make additions or changes without any notice. The products in the catalogue are standard; any enquiry of special applications is evaluated by technical/sales department. The complete documentation belongs to VEP Automation S.r.l. and without permission any kind of reproduction is forbidden.

VEP Automation Headquarters

VEP Automation S.r.l

Via San Felice, 37
10092 Beinasco – Torino (Italy)
Tel. +39 011 3972572
Email: info@vepautomation.it
Web: www.vepautomation.it

VEP Automation Germany

VEP Automation GmbH

Fritz Liebsch Str. 29
D 26723 Emden (Germany)
Tel. +49 04921 450758
Email: info@vepautomation.de
Web: www.vepautomation.de

VEP Automation America

VEP Automation S.A. de C.V.

Av. Toluca 373 - 3A Col. Olivar de los
Padres Del. Álvaro Obregón
01780 CDMX – (Ciudad de México)
Tel. +52 55 8582 8025
Email: info@vepautomation.mx
Web: www.vepautomation.mx

VEP Automation China

柯莱普自动化科技有限公司

苏州柯莱普自动化科技有限公司
地址: 中国江苏省苏州市吴中区友新路 168 号
张玲大厦 2 幢 333 室
Tel.: +86 0512 65753608
Email: info@vepautomation.cn
Web: www.vepautomation.cn